

Sol. Voltage across 35Ω is $22 - 15 = 7$ volt

$$V = IR$$

$$7 = I(35)$$

$$I = \frac{1}{5} \text{ Amp}$$

$$\text{Current } (I_1) \text{ in } 90\Omega = \frac{15}{90} = \frac{1}{6} \text{ Amp}$$

$$\text{So current in Zener diode} = \frac{1}{5} - \frac{1}{6} = \frac{6-5}{30} = \frac{1}{30} \text{ Amp}$$

$$\text{Power} = VI = 15 \times \frac{1}{30} = \frac{1}{2} \text{ watt}$$

$$10P = 10 \times \frac{1}{2} = 5 \text{ watt}$$

5. A simple pendulum attached to ceiling of lift has time period T when lift is at rest. Find its time period of lift if it starts accelerating upwards with acceleration $g/2$?

- (1) $\sqrt{\frac{2}{3}}T$ (2) $\frac{\sqrt{2}}{3}T$ (3) $\frac{2}{\sqrt{3}}T$ (4) $\frac{T}{3}$

Ans. (1)

Sol. $T = 2\pi\sqrt{\frac{\ell}{g}}$

$$T' = 2\pi\sqrt{\frac{\ell}{g + \frac{g}{2}}} \quad \therefore \frac{T'}{T} = \sqrt{\frac{g}{\frac{3g}{2}}}$$

$$T' = T\sqrt{\frac{2}{3}}$$

6. Find acceleration of block:

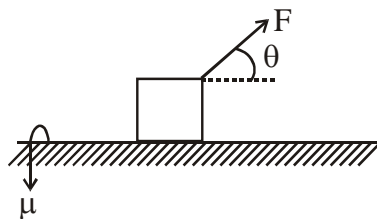

(1) $\frac{F}{m}\cos\theta - \mu\left(g - \frac{F\sin\theta}{m}\right)$

(2) $\frac{F}{m}\cos\theta - \mu\left(g + \frac{F\sin\theta}{m}\right)$

(3) $\frac{F}{m}\cos\theta - \mu\left(g - \frac{F\sin\theta}{2}\right)$

(4) $\frac{F}{m}\cos\theta - \mu g$

Ans. (1)

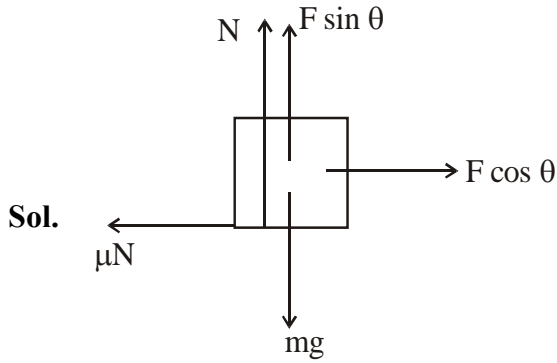

$$a = \frac{F \cos \theta - \mu(mg - F \sin \theta)}{m}$$

$$a = \frac{F}{m} \cos \theta - \mu \left(g - \frac{F \sin \theta}{m} \right)$$

7. In photoelectric effect stopping potential for electromagnetic radiations depends on

- (1) Amplitude (2) Intensity
 (3) Phase (4) Frequency

Ans. (4)

8. If a capacitor C_0 has plate area A and distance between plates is 'd'. Now a dielectric of dielectric constant 'k' is placed between capacitor as shown in figure. Find new capacitance :

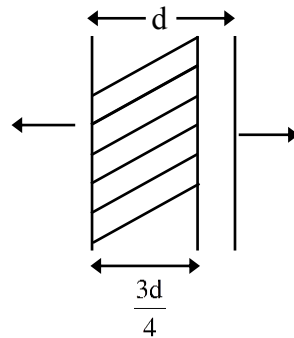

- (1) $\frac{4kC_0}{(k+3)}$ (2) $\frac{3kC_0}{(k+4)}$ (3) $\frac{(k+3)C_0}{4k}$ (4) $\frac{3kC_0}{(k+4)}$

Ans. (1)

Sol. $C_0 = \frac{\epsilon_0 A}{d}$

$$C_{eq} = \frac{C_1 C_2}{C_1 + C_2} = \frac{\frac{k \epsilon_0 A}{\frac{3d}{4}} \times \frac{\epsilon_0 A}{\frac{d}{4}}}{\frac{k \epsilon_0 A}{\frac{3d}{4}} + \frac{\epsilon_0 A}{\frac{d}{4}}} = \frac{\frac{k \epsilon_0 A \times 16}{3d}}{\left(\frac{k}{3} + 1 \right) \times 4} = \frac{4k \epsilon_0 A}{d(k+3)} = \frac{4kC_0}{(k+3)}$$

9. Four small balls are placed at the corner of a square of length ℓ . Evaluate MOI of system about a line passing through A and parallel to BD.

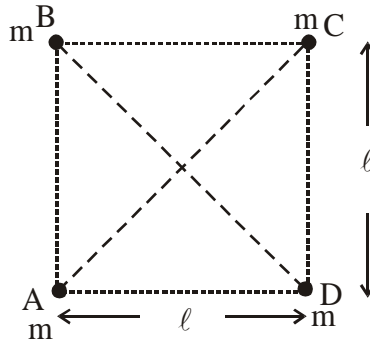

- (1) $\sqrt{3}m\ell$ (2) $3 m\ell^2$ (3) $2 m\ell^2$ (4) $m\ell^2$

Ans. (2)

Sol. $I = 2 m \left(\frac{\ell}{\sqrt{2}} \right)^2 + m (\sqrt{2}\ell)^2$

$$\frac{2m\ell^2}{2} + 2m\ell^2$$

$$3m\ell^2$$

10. Three gases O_2 , N_2 and CO_2 having masses 16g, 28g and 44g respectively are filled in a container of volume V . Evaluate total pressure if temperature of the gases is T .

- (1) $\frac{3 RT}{2 V}$ (2) $\frac{RT}{V}$ (3) $\frac{2 RT}{5 V}$ (4) $\frac{5 RT}{2 V}$

Ans. (4)

Sol. $PV = \left(\frac{16}{32} + \frac{28}{28} + \frac{44}{44} \right) RT$

$$P = \frac{5 RT}{2 V}$$

11. Current through $5k\Omega$ is x mA Find x ?

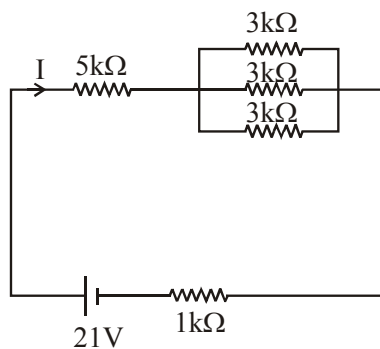

Ans. 3mA

Sol. $i = \frac{21}{R_{eq}} = \frac{21}{7 \times 10^3} = 3 \times 10^{-3} = 3\text{mA}$

12. Disc ($m = 2\text{kg}$)

$R = 0.2$ meter

Disc is initially at rest. Find the number of revolution completed in achieving angular speed 50 rad/sec.

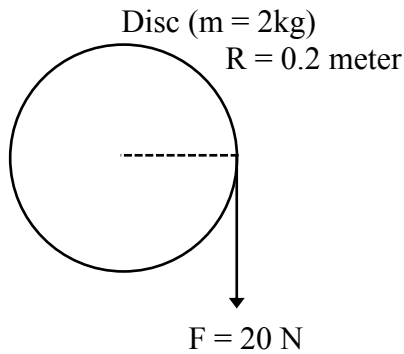

Ans. 2

Sol. Given 1 revolution = 6.283 radian

Mass of disc = 20 kg

Radius = 0.2 meter

$$\tau = I\alpha$$

$$F.R. = I\alpha$$

$$20 \times 0.2 = \frac{2 \times 0.2 \times 0.2 \times \alpha}{2}$$

$$\alpha = 100 \text{ rad/s}^2$$

$$\omega^2 = \omega_0^2 + 2\alpha\theta$$

$$(50)^2 = 2 \times 100 \times \theta$$

$$\theta = 12.5 \text{ rad}$$

$$N = \frac{12.5}{2\pi} \approx 2 \text{ turns}$$

13. An antenna of length 25 m is mounted on top of a building of height 75 m. Then the maximum wavelength of the transmission signal is close to :

- (1) 100 m (2) 200 m (3) 300 m (4) 400 m

Ans. (1)

Sol. Length of antenna $\geq \frac{\lambda}{4}$

$$\lambda \leq 4 \times 25$$

$$\lambda \leq 100 \text{ m.}$$

14. A particle undergoing rectilinear motion has its velocity vs distance travelled as shown below.

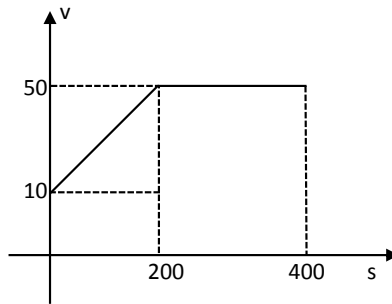

Draw its acceleration vs distance graph?

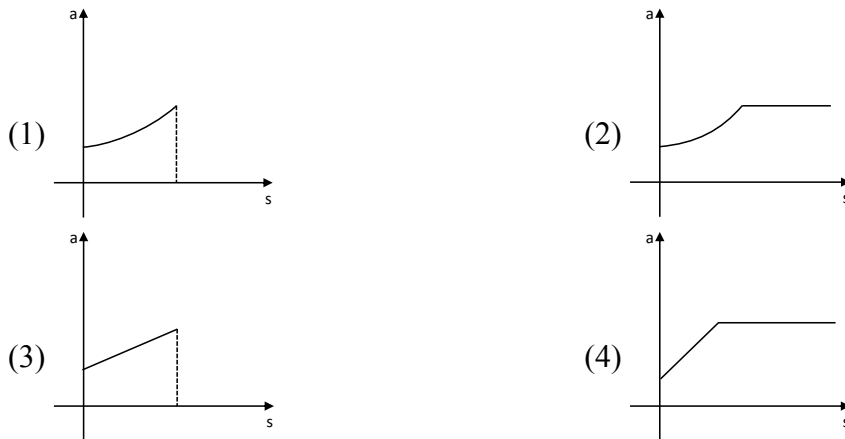

Ans. (3)

Sol. In interval, 0 to 200m,

$$v = \frac{15}{5} + 10$$

15. If a resistance less rod is moving with constant velocity v in a constant magnetic field. Then direction of current I_1 and I_2 in resistance R_1 and R_2 respectively is :

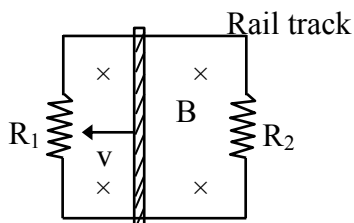

- | | |
|--|--|
| (1) $I_1 \rightarrow$ clockwise, $I_2 \rightarrow$ Anticlockwise | (2) $I_1 \rightarrow$ Anticlockwise, $I_2 \rightarrow$ Clockwise |
| (3) I_1 and I_2 both clockwise | (4) I_1 and I_2 both Anticlockwise |

Ans. (1)

Sol.

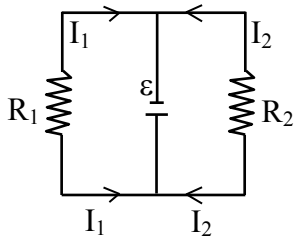

16.

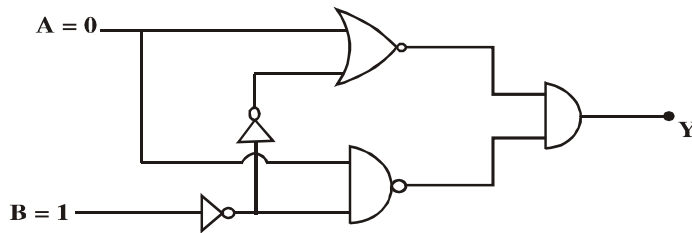

Find output Y ?

Ans. 0

Sol. Theoretical.

17. In a given Isosceles prism for minimum deviation, which of the following statements are true.

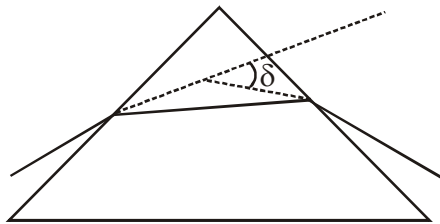

Statement (A) : Ray in the prism is parallel to the base

Statement (B) : Incident Ray & Emergent Ray are symmetric

Statement (C) : $\angle I = \angle E$

Statement (D) : $\angle I = 2\angle E$

- (1) B & C are true
- (2) D is true
- (3) A, B, C are true
- (4) A, D are true

Ans. (3)

Sol. Theoretical

18. In the circuit shown in figure input source is periodic and its wave form is

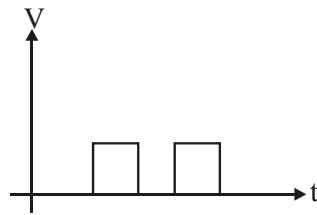

Find the reading of cathode ray oscilloscope (CRO) is

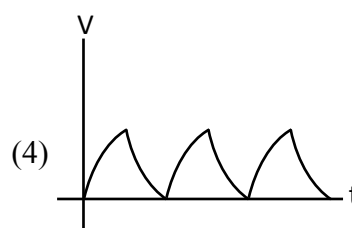
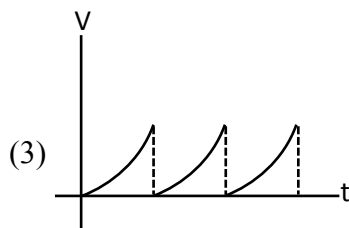
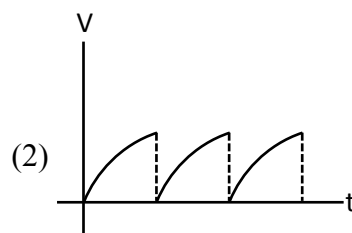
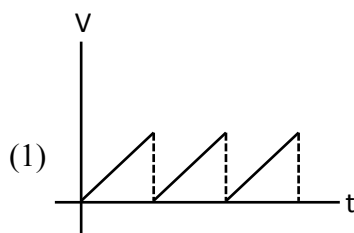
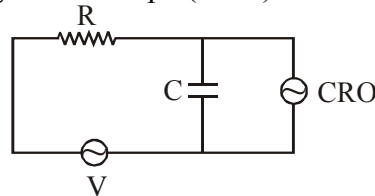

Ans. (4)

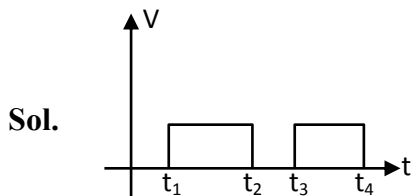

for $t_1 - t_2$ charging graph

for $t_2 - t_3$ discharging graph

19. In YDSE $D = 10$ m, $d = 1$ mm and fringe width of interference pattern is 0.6 nm evaluate λ (in nm)

Ans. 600

Sol. $0.6 \times 10^{-3} = \frac{10 \times \lambda}{10^{-3}}$

$$\lambda = 0.6 \times 10^{-7} \text{ m}$$

$$= 600 \times 10^{-9} \text{ m}$$

$$= 600 \text{ nm}$$

20. A bar magnet of length 14 cm is placed along N-S direction with north of magnetic along north direction. If horizontal component of earth magnetic field is 0.4 G. If at distance 18 cm from centre of magnet a null point is located. Then magnetic moment of magnet is :
- (1) 2.88 Am² (2) 1.88 Am² (3) 4.88 Am² (4) 3.88 Am²

Ans. (1)

Sol.

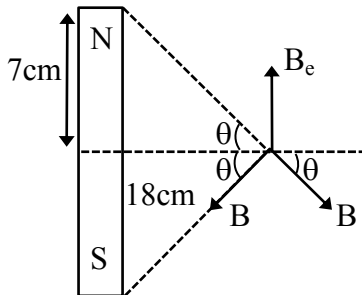

$$B_e = 2B \sin\theta$$

$$B_e = \frac{2 \times \mu_0}{4\pi} \frac{m}{r^2} \times \frac{7 \times 10^{-2}}{r}$$

$$= 0.4 \times 10^{-4}$$

$$M = m \times 14 \times 10^{-2} = 0.4 \times 10^3 r^3$$

$$= 2.88 \text{ Am}^2$$

21. A particle of mass rotates in a circle which has a vertical boundary of radius 0.2 meter, rotating in horizontal plane. Mass of the block is 200 gram. It takes 40 second in one complete revolution. Find the normal force on block.

- (1) 9.8×10^{-4} N (2) 9.8×10^{-2} N (3) 9.8 N (4) 9.8×10^2 N

Ans. (1)

Sol. $N = m\omega^2 R$

$$= (0.2) \left[\frac{4\pi^2}{T^2} \right] (R)$$

$$= (0.2) \frac{4(9.8)}{1600} (0.2)$$

$$= 9.8 \times 10^{-4} \text{ N}$$

22. A particle of mass $m_1 = m$ moving with velocity $10\sqrt{3} \text{ m/s } \hat{i}$ collides with a particle of mass $m_2 = 2m$ at rest. After collision m_1 comes to rest and m_2 breaks into two equal parts such that one part has velocity $10 \text{ m/s } \hat{j}$ then find the angle the velocity vector of other part makes with x-axis in degrees.

Ans. 30

Sol. $\vec{p}_f = \vec{p}_i$

$$M \times 10 \hat{j} + m \vec{v} = m \times 10\sqrt{3} \hat{i}$$

$$\vec{v} = 10\sqrt{3} \hat{i} - 10 \hat{j}$$

23. A planet is revolving around sun in elliptical orbit. Maximum & minimum distance of planet from sun are respectively 1.6×10^{12} m and 6×10^{10} m. Find minimum speed if maximum speed of planet is 8×10^4 m/s?

- (1) 3×10^4 m/s (2) 3×10^3 m/s (3) 8×10^3 m/s (4) 4×10^4 m/s

Ans. (3)

Sol. $L = m v_{\max} r_{\min} = m v_{\min} \times r_{\max}$
 $\therefore 8 \times 10^4 \times 6 \times 10^{10} = v_{\min} \times 1.6 \times 10^{12}$
 $\therefore v_{\min} = 3 \times 10^3$ m/s

24. In L-C-R series circuit at resonance, power dissipated in circuit, (in kW) will be , if peak value of voltage is 250 V and resistance is 8Ω .

Ans. 4

Sol. $P = \frac{V_{\text{rms}}^2}{R} = 3.9 \times 10^3$ kW = 4 kW

25. Ratio of wave-length of first line and third line of Balmer series, is $\frac{x}{10}$ then value of x is.

Ans. 15

Sol. $\frac{1}{\lambda} = RZ^2 \left[\frac{1}{2^2} - \frac{1}{n^2} \right]$
 first line $[3 \rightarrow 2] \Rightarrow \frac{1}{\lambda_1} = RZ^2 \left[\frac{1}{2^2} - \frac{1}{3^2} \right] = RZ^2 \left[\frac{5}{36} \right]$
 3rd line $[5 \rightarrow 2] \Rightarrow \frac{1}{\lambda_2} = RZ^2 \left[\frac{1}{2^2} - \frac{1}{5^2} \right] = RZ^2 \left[\frac{21}{100} \right]$
 $\frac{\lambda_1}{\lambda_2} = \frac{\frac{36}{5}}{\frac{21}{100}} = \frac{36}{5} \times \frac{100}{21} = 1.512 = \frac{x}{10}$
 $x = 15.12$

26. If a EM wave traveling in vacuum in y-direction has magnetic field $\vec{B} = 8 \times 10^{-8} (\hat{k})$. Then value of electric field \vec{E} is:

- (1) $24(\hat{i})$ (2) $24(-\hat{i})$ (3) $2.6 \times 10^{-16}(-\hat{i})$ (4) $2.6 \times 10^{-16}(\hat{i})$

Ans. (2)

Sol. $E_0 = B.C$

$$E_0 = 8 \times 10^{-8} (3 \times 10^8) = 24$$

direction of wave travelling is in $\vec{E} \times \vec{B}$ so $(-\hat{i}) \times \hat{k} = +\hat{j}$

27. A conductor of length L and area of cross section A and resistivity ρ is connected to a battery of voltage V , the current measured is I . What will be the value of current passing through another conductor of length $2L$ and area $\frac{A}{2}$ of same resistivity and connected with same voltage V .

- (1) I (2) $4I$ (3) $\frac{I}{4}$ (4) $2I$

Ans. (3)

28. Coming soon.

29. Coming soon.

30. Coming soon.